



MODEL

2445

HIGH
TEMPERATURE
PORTABLE
AIR VELOCITY
METER



CE



KURZ
INSTRUMENTS INC.™

DESCRIPTION

The Model 2445 is a rugged, accurate and reliable thermal anemometer for a wide variety of very high temperature (500°C) industrial applications. The Model 2445 is mainly used for velocity, flow rate and temperature traverse measurements in larger pipes, ducts and stacks. Most applications are coal-fired power plant stacks, primary and secondary air ducts. It has a fixed-length sensor support and uses the "FD-HHT" sensor with mineral-insulated (MI) sensor cable. Because of its rugged all-welded construction and larger size, the Model 2445 can be used in dirty and corrosive environments. The active sensor support is rated for 500°C; the "handle" is rated for 200°C. Model 2445 includes the Display Module, Carrying Case, battery charger and a separate rugged carrying case for the probe. Options include a vehicle (12 VDC) charger adaptor, I/O Adaptor which plugs into the face of the Display Module and allows digital and analog outputs, traverse data recording, data logging (1500 points) and Modbus ASCII or RTU communications. The Model 2445 is a unique Portable Air Velocity Meter that has tremendous advantages over conventional velocity devices, specially at high temperatures. The Model 2445 represents the state-of-the-art in Industrial quality Portable Air Velocity Meters. Kurz outruns the competition.

KEY FEATURES

- ▶ Easy-to-use menu for display and set-up with HELP screens.
- ▶ Two-line 16 character, back-lit LCD with twenty button keypad.
- ▶ User selected scrolling display.
- ▶ Twenty-four hour clock/calendar, Year 2000 compliance (four digit year).
- ▶ Two optically isolated loop-powered 4-20 mA outputs. User selected for velocity, flow rate or temperature (optional).
- ▶ 1500 Point Data Memory for recording traverses and other measurements.
- ▶ User selected English or Metric units (SFPM, SCFM, SCFH, PPM, PPH, °F; SMPS, SLPM, SCMh, KGM, KGH, °C).
- ▶ Multi-Point calibration correction factors for Flow and Temperature.
- ▶ User-entered METER ID Numbers.
- ▶ User-entered flow area.
- ▶ User selected low velocity cut-off.
- ▶ User selected Reference Conditions (STP).
- ▶ User selected digital time constants for each METER.
- ▶ Built-in flow totalizers and elapsed time.
- ▶ User Access Code.
- ▶ User selected RS-232C or RS-485 Serial port for terminal operation (optional).
- ▶ CE Compliance meeting the European Community requirements for EMI emissions and immunity.
- ▶ Configuration upload/download using a PC.
- ▶ Velocity/Temperature/Mapping (VTM) for wide ranging, process velocity and temperature to 500°C.
- ▶ Nickel-Metal-Hydride 4.5 AH High Performance battery.
- ▶ Battery Charger, 100-240 VAC, 50/60 Hz.
- ▶ Exceptional Temperature Compensation.
- ▶ Flash EEPROM program for user firmware upgrades.
- ▶ Velocity range to 9,000 SFPM.
- ▶ Temperature rating of 500°C.
- ▶ Pressure rating of 300 PSIG.
- ▶ Rugged carrying case for probe and display module and accessories.
- ▶ Dirt Insensitive.
- ▶ Sensor support lengths of 24", 36", 48", 60 and 72".
- ▶ Fastest response to temperatures and velocity changes available.
- ▶ Attitude insensitive.
- ▶ Sensor lead length independent.
- ▶ All components pass an extensive burn-in test for high reliability.
- ▶ Optional Modbus local area network with a read-only control set (Trademark of Square D Company).
- ▶ Electronics operating temperature range of -25°C to +65°C, non-condensing.
- ▶ Excellent low velocity sensitivity.
- ▶ .25% Repeatability.
- ▶ High accuracy over wide velocity and temperature range.
- ▶ Rugged, strong, dependable.
- ▶ Internal and External Data Logging.

APPLICATIONS

- ▶ Combustion Air Velocity and Flow Calibrations.
- ▶ Duct, Stack and Pipe Velocity Traverses.
- ▶ General Purpose Air Flow Measurements.
- ▶ Research and Development.

OUR MISSION

To manufacture and market
the best thermal mass flow meters
available and to support our
customers in their efforts to
improve their business.

MODEL 2445 HIGH TEMPERATURE PORTABLE AIR VELOCITY METER

PRINCIPLE OF OPERATION

The Series 2440 uses the well-recognized Kurz thermal convection mass flow measurement method by detecting the heat transfer from the heated RTD sensor (Rp) referenced to the temperature of the ambient gas stream RTD sensor (Rt). A constant temperature difference between the heated sensor and the temperature sensor is maintained by a modified Wheatstone Bridge circuit in which the heated sensor is the controlled element. This provides unexcelled speed of response and the many other advantages of constant temperature thermal anemometry. The microprocessor-based electronics measures the heat transfer, computes the standard velocity and air temperature, and allows the user to configure and set-up the Series 2440 Display Module. Display screens are easy-to-use and provide all the flow, temperature and diagnostic information. For a more detailed description of Kurz technology, please see Document Number 364003.



Series 2440 Accessories.

Fast Dual-String (FD-HHT) Sensor



TIME RESPONSE TO FLOW AND TEMPERATURE CHANGES

This graph shows the response of a Kurz Fast Dual (FD) MetalClad™ sensor to a step change in velocity. Kurz manufactures the fastest industrial quality sensors available.

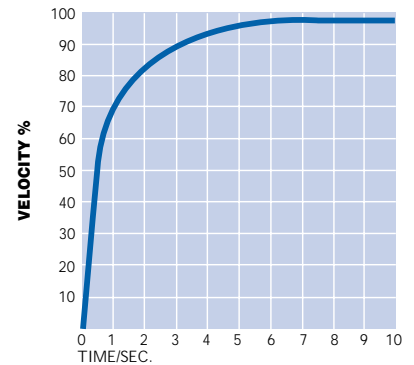

This graph shows a typical response to a step change in temperature for a Kurz Fast Dual (FD) MetalClad™ sensor. It is exceptional and allows use of the sensor for combustion air flow measurements in boilers that mix hot and cold air for temperature control in coal pulverizers, for example.

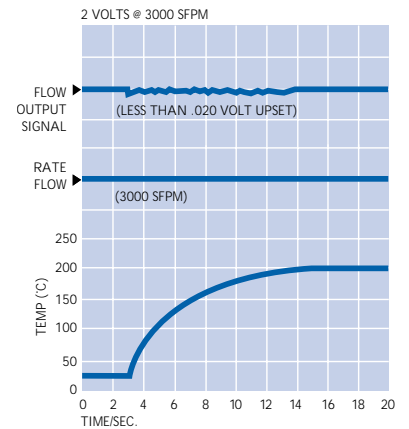

ORIENTATION EFFECTS

The graph shows a typical output response to changes in the incoming velocity direction. Data is shown for rotation and yaw, as defined by the diagram below. Note that the effect is small for angles up to ±20 degrees. This is extremely important for flow applications having severe turbulence and a non-axial velocity direction.

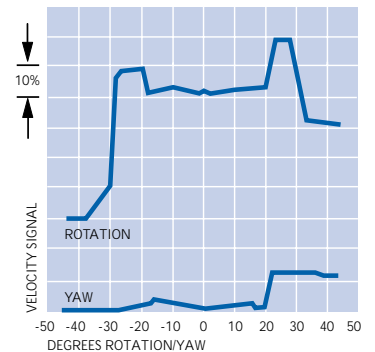

Sensor Measurement Error Versus Rotation/Yaw Angles.

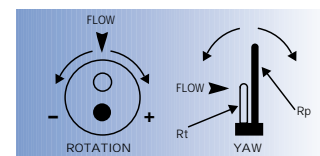

Sensor Rotation and Yaw Description.

SPECIFICATIONS**Velocity Range:**

Standard: 0-9,000 SFPM

Process Temperature Rating:

-40°C to 500°C
(-40°F to 932°F)

Process Pressure Rating:

300 PSIG

Sensor Material:

Alloy C-276 Stings with
Carpenter 20 Cb-3 sensor
base; optional Titanium
Nitride Coating

Sensor Support Material:

316L Stainless Steel

Repeatability: 0.25%**Velocity Time Constant:**

1 S for velocity changes
at 6000 SFPM at a constant
temperature and 1 S for
temperature changes at a
constant velocity of 6000
SFPM.

Process Temperature

Time Constant: 8 second
at a velocity of 6000 SFPM.

Velocity Accuracy:

See Feature 6 for overall
accuracy including the
effects of process
temperature.

Temperature Accuracy:

±(1/2% of Reading + 1°C)
for velocities above 100
SPFM.

Batteries: Nickel-Metal-
Hydride 4.6 AH, 6 cells.

Charger:

100-240 VAC, 50/60 Hz.

Display Module:

Aluminum, Stainless Steel
handle with 3 positions.

Display Module**Temperature Rating:**

-25°C to +65°C,
non-condensing.

Carrying Cases: Two foam-
lined plastic with handles,
one for display module,
one for probe.

Net Weight: 20 pounds.

Shipping Weight: 25 pounds.

Continued on Facing Page

TECHNICAL DESCRIPTION**SENSOR DESIGN**

The Model 2445 uses the exceptional FD-HHT MetalClad™ all-welded Alloy C276 sensor. In this design, the temperature sensor and velocity sensor are mounted in separate tubes (or "stings"), providing exceptional thermal isolation from the sensor support structure and fast response to process temperature changes.

SENSOR MATERIALS AND CONSTRUCTION

The standard sensor material for all Kurz metal sensors is Alloy C-276. This material is far superior to 316 Stainless Steel in high temperature and corrosive applications. Kurz offers Titanium Nitride coating for abrasive, dirty applications, such as in boiler coal pulverizers. Kurz exclusively used Inconel sheathed mineral-insulated sensor cable with a hermetic seal for temperatures to 500°C (HHT construction).

PROCESS TEMPERATURE RATING

The FD-HHT sensor temperature rating is 500°C.

PROCESS TEMPERATURE COMPENSATION

The influence of temperature on the thermal properties of gases requires temperature compensation for repeatable and accurate measurements. Since the Model 2445 is used for a wide range of velocity and temperatures, Velocity/Temperature/Mapping (VTM) is used. VTM includes taking velocity calibrations at two or more process temperatures and using the microprocessor to calculate the velocity based on the built-in process temperature measurement. See Feature 6.

AIR VELOCITY CALIBRATION

Air calibrations are performed in the Kurz Model 400D NIST traceable wind tunnel.

SENSOR PROTECTION

Series 2440 electronics includes circuitry to prevent an over-temperature condition caused by a sensor, wiring or component failure. Our sensors will not overheat at zero flow, unlike most competitive devices because of our constant temperature sensor control method and the power limiting design.

VARIABLE PROBE LENGTH

The standard sensor support lengths are 24", 36", 48", 60" and 72" and include a 6" long "handle" that is rated to 200°C. Model 2444 extensions can be used to extend the "handle".

MICROPROCESSOR

Z180, 18 MHz.

SENSOR ELECTRONICS

The Series 2440 has several innovations which improve performance, reduce cost and provide extraordinary flexibility. A new constant temperature bridge circuit includes an efficient switching power supply and allows the microprocessor to calculate the process gas temperature directly using the temperature compensation sensor. The bridge PCB has an EEPROM loaded with the PCB serial number, calibration coefficients, and component values which insure the safety of the data. The sensor electronics includes a sensor lead resistance compensation circuit which is extremely important for long sensor wires, rapid gas temperature changes and large temperature gradients between the sensor and the ambient air.

ANALOG-TO-DIGITAL CONVERTER

A serial 16-bit ADC provides excellent resolution and noise rejection. To minimize noise the user can select the ADC sample rate for 50 Hz or 60 Hz to provide the best noise rejection.

MENUS

The Display, Executive and Programming menus are very easy-to-use and are largely self-explanatory. The flow and temperature data may be scrolled so it can be seen through the window in the cover. The user may press "D" and see the flow and temperature data, as well as the raw flow data. Pressing "H" holds the display screen (but not the readings). A user access code is required for programming, seeing data and entering configuration and other user data.

INTERNAL DATA RECORDING

Series 2440 includes memory to record 1500 data points. This allows the user to record velocity and temperature traverses, for example, and view the data by using the Display/Keypad.

SPECIFICATIONS Cont'd**Meter Filter Time****Constant:**

User Selected 0 to 600 seconds.

EMI Approvals:

CE Compliance light industrial (EN50081-1) for emissions, heavy industrial (EN 50082-2) for Immunity and (EN 61000-4-5) for surges.

Serial Port Baud Rate:

1200, 2400, 4800, 9600, 14000, 19200, 38400.

Analog Outputs**(4-20 mA):**

Optically isolated, user loop-powered, 12 bit resolution and accuracy, maximum loop-resistance is 500 at 18VDC, 800 at 24VDC, 1400 at 36VDC; meets NAMUR NE43 recommendations.

Digital Outputs:

RS-232 Port for Upload, Download, Record, Echo using user's PC; RS-485 communication port, with Modbus ASCII or RTU Mode. Requires I/O plug-in adapter module.

LCD: Back-lit two-line alphanumeric with 16 characters per line.

LCD Update:

Every two seconds.

Keypad:

20-button membrane.

Memory:

EEPROM for all important data, with automatic sensor identification; Flash EEPROM for Program Memory.

Reference Conditions:

Air at 77°F, 14.69 PSIA, user selected.

Units: User selected English or Metric.

Data Recording:

1500 sets with time and date.

Microprocessor:

18 MHZ, Z180

Analog-to-Digital**Conversion:**

16 bit, user selected 50 or 60 Hz sample rate.

Environment:

Industrial quality air, relative humidity to 99%.

TECHNICAL DESCRIPTION Cont'd**HELP SCREENS**

By pressing "HH" the user can obtain important information on the use of the Series 2440 including the firmware version, Kurz telephone and fax numbers and the web site address, etc.

FLASH EEPROM PROGRAM MEMORY

The program may be updated in the field by the user using the RS-232 port. This new feature will allow our customers to upgrade to the latest firmware.

SELF DIAGNOSTICS

The Series 2440 performs an extensive check-out upon power-up, and continuously monitors the sensor inputs/outputs and verifies the integrity of the sensor wiring and the measurements. The Sensor Kick-Out feature is used to set the fault limits.

METER FILTER TIME CONSTANT

A digital filter time constant may be set for each METER which affects the display readings and the 4-20 mA outputs. The time constant may set from 0 to 600 seconds.

METER SET-UP

The Series 2440 has three "METERS". METER 01 is Velocity, METER 02 is Flow Rate, METER 03 is Temperature. If the area of a duct or pipe is programmed then the measured velocity will be multiplied by the area to give the flow rate, flow totalization and elapsed time. If In-Situ Flow Calibration Data is taken, the user can enter this "reference" data and the test data points, and the microprocessor will calculate the multipoint correction factors and present the corrected flow rate. A sensor blockage correction can also be entered.

STP CONDITIONS

The mass flow calibration data is referenced to the Kurz laboratory standard of 77°F/14.69 PSIA (25°C/760 mmHg). The user may change the STP conditions to suit his requirement in either English or Metric Units.

BAUD RATE SELECTIONS

The user may set the RS 232/RS 485 baud rate to 1200, 2400, 4800, 9600, 14400, 19200, or 38400.

4-20 mA OUTPUTS

These loop-powered outputs are optically isolated, and include the NAMUR NE43 recommendation regarding fault detection. The fault conditions are set at the Kurz Factory, but may be set by the user. The user may easily calibrate the 4-20 mA outputs by entering the Output Calibration menu, measuring the output and adjusting it using the LCD/Keypad. See Feature 7.

LOW VELOCITY CUT-OFF

The user may select a low velocity cut-off value such as 20 SFPM to eliminate nuisance readings.

BACK-LIT LCD SWITCH

This momentary switch is on the display module.

BATTERY VOLTAGE DISPLAY

The user can touch "D" on the keypad and scroll through the METER data and also see the battery level. A fully charged battery will operate for about 2-1/2 hours at 4000 SFPM and 500°C. If the battery is disconnected, the Display Module will operate continuously on the battery charger.

FIRMWARE

The Series 2440 firmware supports:

- ▶ Remote Terminal Operation of the Display Module via RS-232 or RS 485.
- ▶ Data Transfer of the internal logged data to a PC in a spreadsheet compatible format.
- ▶ METER Summary Command (L) for external data logging from any computer. See the PC Data Logging Program, PN 451029.
- ▶ External/Remote data logging via Modbus RTU or ASCII protocol. See Feature 7 for details.

MODEL 2445 HIGH TEMPERATURE PORTABLE AIR VELOCITY METER

ORDERING INFORMATION

The Selection Table below lists the Model Number, Parent Number and Technical Data.

MODEL 2445 SELECTION TABLE					
Model Number	Parent Number	Sensor Support Diameter	Process Temperature Rating	Process Pressure Rating	Sensor Type
2445	754050	3/4"	500°C	300 PSIG	FD-HHT

NOMENCLATURE:

PROCESS TEMPERATURE RATING		
Identifier	Description	Range
HHT	Very High Temperature	-40°F to 932°F
		-40°C to 500°C

SENSOR TYPE			
Identifier	Description	Time Response ¹	Applications
FD-HHT	Fast Dual-MetalClad Velocity Sensor, all-welded Alloy C-276 construction	Velocity: 1 Sec. Temperature: 1Sec.	Pipe/Ducts, Velocity Traverses, Dirty Air, Fast Changing Gas Velocity and Temperature, Pipe I.D. 2.5" and larger.

Note 1: Time response is the time required to attain 63% (1 time constant) of the original reading after a step change in process temperature in constant velocity, or a step change in velocity at constant process temperature at an initial mass velocity of 6000 SFPM.

PART NUMBER GENERATION PROCEDURE

Specify the entire Part Number using the Parent Number followed by an Option for each Feature as shown in the Part Number example below. Feature Options printed in bold type indicate the standard product, other options usually require a longer delivery time.

754050 - 13 - 27 - 12 - 18 - 01 - 26 - 10

Parent Number - F1 - F2 - F3 - F4 - F5 - F6 - F7

SUMMARY OF FEATURES	
Feature	Feature Description
1	Sensor Type/Sensor Material
2	Sensor Support Material/Length
3	Sensor Cable Material/Length
4	Gas Velocity Calibration Data Range
5	Specialty Gas Velocity Calibration
6	Process Temperature Compensation
7	I/O Adapter, Digital Outputs/4-20 mA Outputs

FIRST DIGIT OF FEATURE 1: SENSOR TYPE	
Option	Description
1	FD-HHT

SECOND DIGIT OF FEATURE 1: SENSOR MATERIAL	
Option	Description
3	Alloy C-276 Sensor Stings
7	Titanium Nitride Sensor Coating on Option 3 material

FIRST DIGIT OF FEATURE 2: SENSOR SUPPORT MATERIAL	
Option	Description
2	316L Stainless Steel

SECOND DIGIT OF FEATURE 2: SENSOR SUPPORT LENGTH (NOTE 1)	
Option	Support Length L
4	24"
5	36"
6	48"
7	60"
8	72"

Note 1: The Sensor Support Length (L) does not include the length of the sensor protection "window" (2.78") and the 6" long "handle", which is limited to 200°C.

FIRST DIGIT OF FEATURE 3: SENSOR CABLE MATERIAL	
Option	Description
1	Teflon Insulated Cable

SECOND DIGIT OF FEATURE 3: SENSOR CABLE LENGTH (NOTE 1)	
Option	Description
2	12 Feet

Note 1: For a longer cable purchase an extension cable (8', 16', 24') which gives a great deal of flexibility and convenience. See the Series 2440 Accessories.

FEATURE 4: GAS VELOCITY CALIBRATION RANGE

The velocity data is taken in English Units and Standard Reference Conditions (STP) of 77°F and 14.69 PSIA. If Metric Velocity units or a different STP is required, the user can easily change the STP Reference, and select English or Metric Units using the Display/Keypad. A sufficient number of calibration data points are taken to ensure accuracy over the entire range.

FEATURE 4: GAS VELOCITY CALIBRATION DATA RANGE	
Option	Description
16	9,000 SFPM

FEATURE 5: SPECIALTY GAS VELOCITY CALIBRATION	
Option	Gas Type
01	Air

FEATURE 6: PROCESS TEMPERATURE COMPENSATION

The influence of temperature on the thermal properties of gases and the operating temperature of a thermal mass flow sensor requires temperature compensation for repeatable and accurate measurements. Since the process temperature and gas velocity may vary widely, Velocity/Temperature/ Mapping (VTM) is used. VTM includes the standard temperature compensation procedure and velocity calibrations in air at two or more process temperatures. These multiple velocity calibrations are entered into the Microprocessor which performs a double interpolation between the velocity calibration curves using the built-in process gas temperature measurement.

FEATURE 6: PROCESS TEMPERATURE COMPENSATION	
Option	Description
26	Velocity/Temperature/Mapping (VTM) with four calibration data sets over the process temperature range -40°C to +500°C. Accuracy: ±[3% of Reading + (30 SFPM + 0.25 SFPM/°C)], above or below 25°C.

MODEL 2445 HIGH TEMPERATURE PORTABLE AIR VELOCITY METER

FIRST DIGIT OF FEATURE 7: I/O ADAPTER, DIGITAL OUTPUTS	
Option	Description
0	No I/O Adapter Module; no Digital or Analog Outputs.
1	I/O adapter module which plugs into the multi-pin module with a 2 ft. cable. Includes a 6 ft RS-232 cable with the DB9F connectors for connecting between the I/O Adapter and a PC and a third connector used for field upgrades of the firmware. I/O Adapter supports RS-485 or RS-232 and two isolated loop-powered 4-20 mA outputs. Upload/download configuration transfer software is provided for a Windows PC. The Series 2440 firmware supports: <ul style="list-style-type: none"> ▶ Remote terminal operation of the Series 2440 Display Module via RS-232 or RS-485. ▶ Data transfer of the internal logged data to a PC in a spreadsheet compatible format. ▶ METER summary command (L) for external data logging from any computer. (For example, see the Kurz PC data logging program PN 451029) ▶ External/Remote data logging via Modbus, RTU or ASCII protocol.

SECOND DIGIT OF FEATURE 7: 4-20MA OUTPUTS (NOTE 1)		
Option	Number	Description
0	0	No 4-20 mA Outputs.
2	2	Two 4-20 mA Outputs loop-powered, AC/DC optically isolated.

Note 1: Option 1 of the First Digit of Feature 7 must be specified if the 4-20 mA option is ordered.

SERIES 2440 ACCESSORIES	
P/N	Description
150525	Model 2444/2445 Sensor Support Extensions.
260111-01	Series 2440 Sensor Extension Cable, Teflon, 8' long.
260111-01	Series 2440 Sensor Extension Cable, Teflon, 16' long.
260111-03	Series 2440 Sensor Extension Cable, Teflon, 24' long.
320029	Series 2440 Battery, 4.5 AH, six cell, NiMH.
260108	Series 2440 AC Power Cord for Charger.
330046	Series 2440 AC Charger, 100-240 VAC, 50/60 Hz.
260110	Series 2440 Vehicle Charger Adapter, 12 VDC.
420334	Series 2440 I/O Adapter Module.
451029	PC Data Logging Program, CD-Rom, Manual
260102	RS232 Cable, for upload/download, data transfer to PC and Firmware updates.
260106	Series 2440 I/O Adapter Cable.
150540	Model 2444/2445 3/4" MNPS by 5/8"-UNEF Sensor Support Adapter.

ORDERING INFORMATION

Contact the Kurz Representative or the Kurz Factory to place the order or to obtain additional information.

MODEL 2445 OUTLINE DRAWINGS

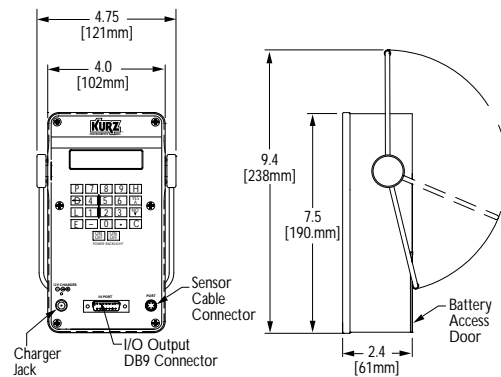

Series 2440 Display Module

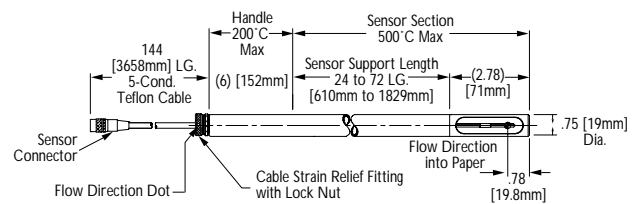

Model 2445 Probe

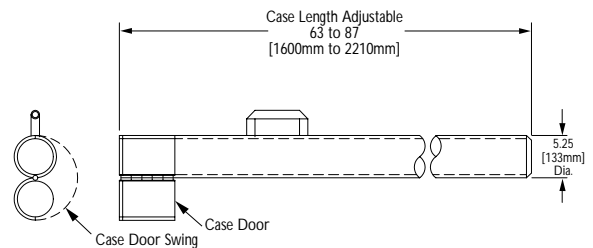

Model 2445 Probe Carrying Case

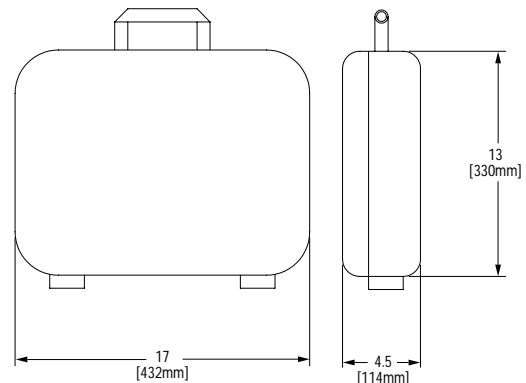

Model 2445 Display Module Carrying Case

**The leader in Mass Flow
Technology for Process and
Environmental Measurements**



Kurz Instruments, Inc.

2411 Garden Road, Monterey, CA 93940

800-424-7356 ■ 831-646-5911 ■ Fax 831-646-8901

www.kurz-instruments.com

e-mail: sales@kurz-instruments.com

