

SERIES 534FTB

IN-LINE THERMAL MASS FLOW TRANSMITTERS

Exceptional Immunity to Upstream/Downstream Velocity Profiles

Timeliness



DESCRIPTION	KEY FEATURES	
<p>Introducing the Series 534FTB In-Line Thermal Mass Flow Transmitters with the advantages of built-in inlet/outlet piping reducers/expanders and exceptional immunity to upstream/downstream flow disturbances caused by elbows, valves and line size changes. The Series 534FTB is the newest addition to the Kurz family of state-of-the-art In-Line Thermal Mass Flow Transmitters for industrial gases. This patented design eliminates the need for field fabrication and assembly of inlet and outlet mating pipe sizes. Each Model offers a choice of three line sizes to meet nearly all applications. The new Series 534FTB has eight basic Models covering mass flow ranges to 2350 SCFM, in line sizes from 1/2" to 8" pipe. This unique design uses special flow nozzles and flow diffusers to obtain flow disturbance immunity without the need for screens, honeycomb or vortex generators providing exceptional low end-to-end pressure drop. Because of this design, the output has very low flow noise, exceptional accuracy, repeatability and turn-down ratio. The 534FTB meets CSA (USA and Canada), and ATEX Non-Incendive and Explosion-Proof/Flame-Proof Safety Standards and are IP66/NEMA 4X/7 Rated. Kurz is an ISO 9001 Quality Manufacturer.</p>	<ul style="list-style-type: none"> ■ Constant temperature sensor control circuit. ■ Sensors and Electronics (single PCB) are interchangeable. No matched sets. ■ 3 Year Warranty. All components pass an extensive accelerated stress test for high reliability. ■ Patented flow body design provides exceptional immunity to upstream and downstream flow disturbances. ■ Built-In Line Size Reducers/Expanders to fit most applications. ■ Velocity profile conditioning using flow nozzles and diffusers. ■ Low Flow Noise. ■ Multi-Point calibration correction factors for Flow and Temperature. ■ Zero velocity is a valid data point. ■ Fastest response to temperature and velocity changes in the industry. ■ Process Temperature Rating of -40°C to +125°C. ■ Process Pressure Rating up to 300 PSIG. ■ Electronics operating temperature range of -40°C to +65°C, non-condensing. ■ Easy-to-use menus for display and configuration including basic setup "Wizard". ■ User configurable scrolling or static displays of Flow process variables. ■ Configuration upload/download software using a PC with USB connection, RS-485 or TCP/IP Modbus ■ Adjustable two-line LCD/Keypad allowing ease of reading the display for horizontal or vertical installations. ■ User selected English or Metric units (SFPM, SCFM, SCFH, PPM, PPH, °F; SMPS, NMPS, NLPM, NCMH, SLPM, SCMH, KGM, KGH, °C). ■ USB port for terminal operation. ■ Modbus ASCII or RTU communications. ■ HART 7 communication option. ■ Alloy C-276 all-welded sensor construction. ■ Integral or Remote Electronics Enclosure ■ IP66/NEMA 4X/7 dual chamber epoxy painted electronics enclosure. ■ Input power options of 85 to 265 VAC 47/63 Hz or 24 VDC. 	<ul style="list-style-type: none"> ■ Two optically isolated loop-powered 4-20 mA outputs which are user configurable. Typically, one is configured for mass flow rate or mass velocity and the other for process temperature or for PID application (Flow transmitters with the HART communication option have only one 4-20mA output). ■ Two optically isolated solid-state alarm/relays (optional). ■ One 4-20mA input (optional). ■ Pulsed output for use as a remote flow totalizer (optional). ■ Meets EPA Mandatory GHG Certification Requirement in CFR98.34(c)(1). ■ 4-20 mA outputs meet NAMUR NE43 recommendations. ■ User programmable Access Codes. ■ User may change STP reference condition without affecting factory calibration data. ■ Sensor lead length independent circuitry. ■ User-selectable digital filtering. ■ Programmable alarm functions. ■ Built-in flow totalizers and elapsed time. ■ Flow Body orientation independent. ■ CE Compliance, including EMC, ATEX, LVD, PED, WEEE and ROHS EU Directives. ■ Non-Incendive and Explosion-Proof/Flame-Proof Safety Approvals (CSA/ATEX/IECEx). ■ HART (Optional)
		<p>APPLICATIONS</p> <ul style="list-style-type: none"> ■ Industrial and process gas mass flow ■ Fuel flow for burners and fuel cells ■ NO_x control using ammonia ■ Aeration air and Digester gas for waste water treatment facilities ■ Compressed air ■ Natural gas ■ Combustion air ■ Metering semi-conductor gases ■ Chlorine metering in the paper industry ■ Solvent and VOC recovery ■ Air sampling ■ General purpose mass flow, R&D ■ Flow calibration standards ■ Nuclear power plants ■ Air sampling in D.O.E. facilities ■ O.E.M. applications

SERIES 534FTB IN-LINE THERMAL MASS FLOW TRANSMITTERS

PRINCIPLE OF OPERATION

The Series 534FTB uses the well-proven Kurz thermal convection mass flow measurement method by detecting the heat transfer from the self-heated RTD sensor (Rp) referenced to the temperature of the ambient gas stream RTD sensor (Rtc). A constant temperature difference between the heated sensor and the temperature sensor is maintained by a patented digital Wheatstone Bridge circuit in which the heated sensor is the controlled element. This provides unexcelled speed of response and the many other advantages of constant temperature thermal anemometry. The microprocessor-based electronics measures the heat transfer, computes the standard velocity and ambient gas temperature, and allows the user to configure and set-up the 534FTB to fit all flow requirements. Display screens are easy-to-use and provide all the flow, temperature and diagnostic information. For a more detailed description of Kurz technology, please see Document Number 364003 "Theory and Application of Kurz Thermal Convection Mass Flow Meters," or by visiting our web site.

VELOCITY PROFILE IMMUNITY

Figure 1—Shows the error due to upstream and downstream flow disturbances caused by 90° elbows and one process pipe line size smaller or larger than the Model 534FTB pipe size.

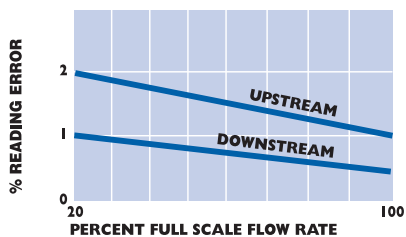

Fig. 1—Typical effect of upstream/downstream flow disturbances.

CALIBRATION CURVE

Figure 2—The basic flow calibration curve is non-linear, having a non-zero output (live zero) at zero flow and a nearly constant percent of reading accuracy. Zero is a valid data point for a Kurz meter.

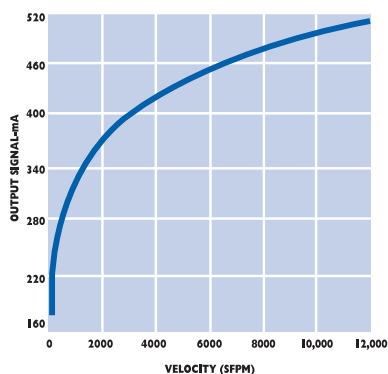

Fig. 2—Calibration Curve.

TIME RESPONSE TO FLOW AND TEMPERATURE CHANGES

Figure 3—Shows the response of a Kurz sensor to a step change in velocity at a constant process gas temperature.

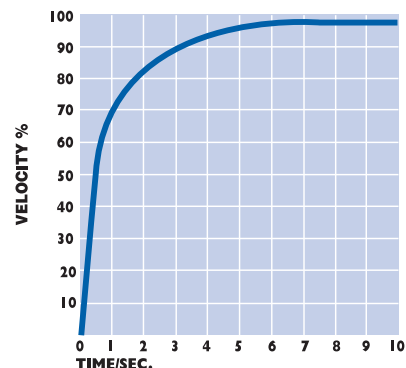

Fig. 3—Sensor Flow Response.

Figure 4—Shows a typical response to a step change in temperature at a constant mass flow rate.

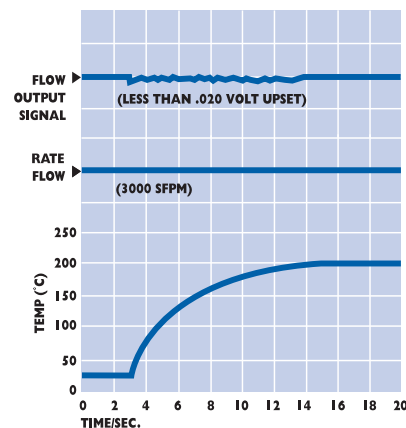

Fig. 4—Sensor Temperature Response.

OUR MISSION

To manufacture and market the best thermal mass flow meters available and to support our customers in their efforts to improve their business.

SPECIFICATIONS	TECHNICAL DESCRIPTION
<p>Process Temperature Rating: -40°C to +125°C</p> <p>Process Pressure Rating: Up to 300 PSIG (20 BARg)</p> <p>Sensor Material: Alloy C-276</p> <p>Flow Body Material: 316L SS</p> <p>Repeatability: 0.25%</p> <p>Velocity Time Constant: 1 second for velocity changes at 6000 SFPM at a constant temperature and 1 second for temperature changes at a constant velocity of 6000 SFPM.</p> <p>Process Temperature Time Constant: 8 seconds at a velocity of 6000 SFPM.</p> <p>Flow Accuracy: See Feature 4 for overall accuracy including temperature effects.</p> <p>Temperature Accuracy: ±(1/2% of reading +1°C) for velocities above 100 SPFM.</p> <p>Power: +24 VDC ±10%, 85-265 VAC ±10% 47-63 Hz; 24 watts max.</p> <p>Enclosure Temperature Rating: -25°C to +65°C for all configurations; -40°C to +65°C for DC units without LCD/Keypad.</p> <p>Enclosure: Dual-Chamber and Single-Chamber Epoxy-Painted aluminum, IP66/NEMA 4X/7 with glass window for display option.</p> <p>Solid-State Relays: Two, optically isolated, .8 ampere, 24 VAC/VDC maximum</p> <p>Analog Outputs (4-20 mA): Optically isolated, user loop-powered, 12 bit resolution and accuracy, maximum loop-resistance is 500Ω at 18 VDC, 800Ω at 24 VDC, 1400Ω at 36VDC; meets NAMUR NE43 recommendations.</p> <p>Meter Filter Time Constant: Selectable 0 to 600 seconds.</p>	<p>FLOW BODY DESIGN</p> <p>The new Series 534FTB flow bodies include a patented unique method (Patent Number US 7,509,880 B2) of minimizing the influence of upstream and downstream pipe size changes, elbows and other flow disturbances, as well as offering the customer three line sizes for each Model Number, thus eliminating the need for adapters, field welding and questionable flow characteristics. A well-formed bell-mouth flow nozzle having a 4:1 area contraction ratio (Beta of 0.5) is used to “flatten” the incoming velocity profile with a minimum loss of energy. The “A” Models use a well-designed flow diffuser upstream of the flow nozzle to reduce the velocity into the flow nozzle with minimum pressure drop and to accommodate the smaller line sizes. The “C” Models use a similar flow diffuser downstream of the flow nozzle to minimize pressure drop for the larger line sizes. The “B” Models use a flow diffuser upstream and downstream of the flow nozzle to accommodate the intermediate line sizes. The net result of this uniquely Kurz design is that the Model 534FTB is highly immune to upstream and downstream flow disturbances, accommodates the need to match existing line size and has a very low end-to-end pressure drop.</p> <p>SENSOR DESIGN</p> <p>Series 534FTB In-Line Mass Flow Transmitters use the Kurz MetalClad™, “MD” and “FD2” all-welded Alloy C-276 sensors. In this design, the temperature sensor and velocity sensor are mounted in separate tubes (or “stings”), providing exceptional thermal isolation from the sensor support structure and a fast response to process temperature changes.</p> <p>PROCESS TEMPERATURE COMPENSATION</p> <p>The influence of temperature on the thermal properties of gases requires temperature compensation for repeatable and accurate measurements. Kurz temperature compensation is the most advanced and is exceptional.</p> <p>GAS CALIBRATION</p> <p>The customer has a choice of a laboratory calibration or a gas correlation calibration for most industrial gases.</p>

Continued on next page

SENSOR PROTECTION

The 534FTB circuitry includes circuitry to prevent an over-temperature condition caused by a sensor, wiring or component failure. Kurz sensors will not overheat at zero flow, unlike most competitive devices because of the constant temperature sensor control and the power limiting design.

SENSOR ELECTRONICS

The Series 534FTB has several innovations which improve performance, reduce cost and provide extraordinary flexibility. The constant temperature digital bridge circuit (US Patent 7,418,878) includes an efficient switching power supply. The single bridge PCB has an EEPROM loaded with the PCB serial number, calibration coefficients, and component values which insures the safety of the data. The sensor electronics includes a sensor lead resistance compensation circuit which is extremely important for long sensor wires, rapid gas temperature changes and large temperature gradients between the sensor and the ambient air.

FIRMWARE

The onboard menu system is easy to use and intuitive. The flow meter data (e.g. velocity, mass rate, volumetric rate, and temperature) can be displayed in a user selectable form and viewed through the window in the cover. A local keypad can be accessed to navigate through the on board menu system to display various flow and diagnostic data as well as enter basic and advanced setup options. A user code is required for programming and entering configuration data or performing test and diagnostic utilities.

SELF-DIAGNOSTICS

The 534FTB performs an extensive systems check upon power-up, and continuously monitors the sensor inputs/outputs and verifies the integrity of the sensor wiring, and the measurements.

PROGRAMMABLE CORRECTION FACTORS

A Multi-Point Variable Correction Factor may be used to correct the flow calibration data to meet in-situ or laboratory flow tests. A Bias Correction Factor (BCF) may also be selected.

SPECIFICATIONS cont'd.

Safety Approvals:

CSA Non-Incendive Approval:
IEC 79-15 and EN60079-0/15

ATEX Non-Incendive Approval:
EN60079-0/15 and EN61241-1

CSA Explosion-Proof Approval:
IEC 79-01 and EN60079-01

ATEX Flame-Proof Safety Approval:
EN 60079-0/1

Note: See Kurz website for the complete Safety Approvals Specifications.

CE Directives:

EMC, ATEX, LVD, WEEE and ROHS Directives for all models. PED Directives for Models 534FTB-06, -08, -12, -16, -24, -32 Consult Kurz for details.

Serial Port Baud Rate:

User selectable: 9600, 14,400, 19,200, 38,400, 57,600.

Communication Ports:

RS485 Modbus ASCII or RTU Mode, and USB.

Analog Input:

One, 4-20mA, non-isolated.

LCD: Back-lit two-line alphanumeric with 16 characters per line.

LCD Update: Every two seconds.

Keypad: 20-button membrane mounted inside enclosure.

LCD/Keypad Orientation:

Adjustable in 90° increments to accommodate viewing orientation.

Electronics Enclosure

Orientation: 0° or 180° for viewing (Feature 1).

Memory: EEPROM for all important data, with automatic sensor identification; Flash EEPROM for Program Memory.

TECHNICAL DESCRIPTION cont'd.

METER FILTER TIME CONSTANT

A digital filter time constant may be set for the flow calculation which affects the displayed values and the 4-20 mA outputs. The time constant can be set from 0 to 600 seconds.

SELECTABLE STP CONDITIONS

The mass flow calibration data is referenced to the Kurz laboratory standard of 77°F/14.69 PSIA (25°C/101.325 kPa). The user may change the STP conditions without affecting the calibration data.

COMPATIBILITY WITH SERIES 155

MASS FLOW COMPUTERS

The 534FTB is fully compatible with the inputs and features of the Series 155 Mass Flow computer. DC powered units can be directly powered by the 155 Computer. This Feature is used when two or more Model 534FTBs are used in a multi-point velocity array. (Please see the Series 155 brochure).

GREENHOUSE GAS REPORTING

Beginning in 2010, the EPA requires certain facilities to report GHG emissions. This rule is contained in US Code of Federal Regulations Title 40, Part 98. Kurz thermal mass flow meters meet the certification requirement in 40 CFR 98.34(c)(1) required by the Mandatory GHG Reporting regulation and are approved for this application.

NAMUR NE43 COMPLIANCE

Kurz meets the NAMUR NE43 recommendation for the 4-20 mA outputs to indicate a sensor or system fault. An NE43 alarm may be selected as high or low (but not both). This feature frees up the alarm/relays so that the user can set-up the relays for other needs.

4-20 mA OUTPUTS

The 4-20mA outputs may be wired as optically isolated loop-powered outputs or non-isolated, self powered outputs. The user may easily re-calibrate the 4-20 mA outputs using the CALIBRATE ANALOG OUTPUT menu in the onboard menu system or through the HART interface.

RELAYS – ALARMS/PULSED

TOTALIZER OUTPUT/PURGE OUTPUT

The 534FTB can be ordered with up to 2 solid-state optically isolated relays. The relay outputs can be user configured to the following functions: alarm outputs or pulsed totalizer output. If no relays are ordered, the alarm functions are displayed on the LCD. Totalizers may be automatically reset at a specific total quantity (i.e., 10,000 SCF).

PID FLOW CONTROLLER

The 534FTB includes the capability of controlling the velocity or flow rate through the use of the user's control valve, damper or position commanded 4-20 mA interface device. The Set-Point may be internal or remote.

USB PORT

A USB port for terminal operations includes a COM emulator driver which can be accessed using a PC terminal emulator program to remotely "echo" the LCD and keypad functions and upload/download the system configuration and calibration data files using XMODEM protocol. Process data may be initiated manually through the Log Mode menu from the remote terminal/keyboard or the local LCD/keypad. The information may also be obtained automatically by configuring the Serial Data Logging through the onboard menu system.

HART

The Series 534FTB can be ordered with the HART communication interface. The HART protocol is a recognized and accepted standard in the process control industry. This interface provides the following benefits: remote configuration, remote diagnostic monitoring and on-line testing using available hand held configurators.

MODBUS

The Modbus local network protocol (ASCII or RTU) is included. The use of Modbus is extremely useful, as most features may be accessed, including configuration upload, download, etc.

ANALOG INPUT

One non-isolated, 4-20mA.

SERIES 534FTB IN-LINE THERMAL MASS FLOW TRANSMITTERS

ORDERING INFORMATION

FLOW TRANSMITTER SELECTION:

Table 1 lists the Series 534FTB Model Number, Parent Numbers, Inlet/Outlet Size, Length, Sensor Type, and Flow Area. **Table 2** lists the Baseline (Q*) Full Scale Flow Rate for each Gas Type. **Table 3** lists the Flow Factor (F*) Equations for each Gas Type. **Table 4** lists the Standard Pressure Drop at the Baseline (Q*) Flow Rate for each Gas Type.

TABLE 1: SERIES 534FTB IN-LINE MASS FLOW TRANSMITTERS					
Model Number	Parent Number	Inlet/Outlet Pipe Size	Length (Note 1)	Sensor Type	Flow Area A* (FT²)
534FTB-06A	755438	½"	9"	MD	.00045
534FTB-06B	755439	¾"	9"	MD	.00045
534FTB-06C	755440	1"	9"	MD	.00045
534FTB-08A	755441	½"	15"	MD	.00158
534FTB-08B	755442	¾"	15"	MD	.00158
534FTB-08C	755443	1"	15"	MD	.00158
534FTB-12A	755444	¾"	20"	MD	.00341
534FTB-12B	755445	1"	20"	MD	.00341
534FTB-12C	755446	1½"	20"	MD	.00341
534FTB-16A	755447	1"	26"	MD	.00590
534FTB-16B	755448	1½"	26"	MD	.00590
534FTB-16C	755449	2"	26"	MD	.00590
534FTB-24A	755450	1½"	38"	MD	.01466
534FTB-24B	755451	2"	38"	MD	.01466
534FTB-24C	755452	3"	38"	MD	.01466
534FTB-32A	755453	2"	48"	MD	.02454
534FTB-32B	755454	3"	48"	MD	.02454
534FTB-32C	755455	4"	48"	MD	.02454
534FTB-48A	755459	3"	72"	FD2	.05642
534FTB-48B	755460	4"	72"	FD2	.05642
534FTB-48C	755461	6"	72"	FD2	.05642
534FTB-64A	755462	4"	94"	FD2	.09743
534FTB-64B	755463	6"	94"	FD2	.09743
534FTB-64C	755464	8"	94"	FD2	.09743

Note 1: Add 3" to L and 1½" to L1 for MNPT option.

TABLE 2: BASELINE (Q*) FLOW RATE RANGES (See Notes 1, 2, 3)						
FLOW RATE SCFM (NCMH)						
Model Number	GAS CATEGORY AND GAS TYPE					
	1 Air, N ₂ , O ₂ , Ar, CO ₂ , Dry Cl ₂	2 Methane, Digester Gas, Dry Ammonia	3 Ethylene	4 Ethane	5 Helium, Propane, Butane	6 Hydrogen
534FTB-06 A, B, C	8.1 (12.6)	7.7 (12.0)	6.8 (10.6)	6.0 (9.4)	4.5 (7.0)	2.7 (4.2)
534FTB-08 A, B, C	28 (44)	27 (42)	24 (37)	21 (33)	16 (25)	9.5 (14.8)
534FTB-12 A, B, C	61 (95)	58 (90)	51 (80)	45 (70)	34 (53)	20.0 (31)
534FTB-16 A, B, C	106 (165)	100 (156)	88 (137)	78 (122)	59 (92)	35 (55)
534FTB-24 A, B, C	264 (412)	250 (390)	220 (343)	195 (304)	147 (229)	88 (137)
534FTB-32 A, B, C	442 (690)	417 (650)	368 (574)	326 (509)	245 (382)	147 (229)
534FTB-48 A, B, C	1016 (1585)	959 (1496)	846 (1320)	750 (1170)	564 (880)	339 (529)
534FTB-64 A, B, C	1754 (2736)	1656 (2583)	1461 (2279)	1296 (2022)	974 (1519)	585 (913)

Note 1: See Nomenclature for the complete definition of Gas Group Number and Gas Type.

Note 2: SCFM: Standard Cubic Feet-Per-Minute (Ref: 77°F, 14.69 PSIA). NCMH: Normal Cubic Meters-Per-Hour (Ref: 0°C, 760 mmHg). NCMH: 1.56 x SCFM (Approximate).

Note 3: The Baseline (Q*) Flow Rate for each Flow Transmitter Model Number and for each type of gas is the maximum flow rate at standard conditions (See Note 2).

TABLE 3: FLOW FACTOR (F*) EQUATIONS		
Gas Type	DR _p	Equations
Category 1: Air, N ₂ , Ar, CO ₂ , Dry Cl ₂	Less than 1.333	F* = DR _p
	Greater than 1.333	F* = 1.333
Category 2: Methane, Digester Gas, Dry Ammonia	Less than .945	F* = 1.059DR _p
	Greater than 0.945	F* = 1.000
Category 3: Ethylene	Less than .833	F* = 1.2DR _p
	Greater than .833	F* = 1.0
Category 4: Ethane	Less than .739	F* = 1.353DR _p
	Greater than .739	F* = 1.000
Category 5: Helium, Propane, Butane	Less than .555	F* = 1.8DR _p
	Greater than .555	F* = 1.00
Category 6: Hydrogen	Less than .333	F* = 3.0DR _p
	Greater than .333	F* = 1.000

SERIES 534FTB IN-LINE THERMAL MASS FLOW TRANSMITTERS

TABLE 4: ESTIMATED PRESSURE DROP (DP _S) (Note 1)	
Gas Type	Pressure Drop inches water(mm water)
Air	7.5 (190)
Argon	10.3 (262)
Butane	4.6 (117)
Carbon Dioxide	11.3 (287)
Dry Ammonia	4.4 (111)
Dry Chlorine	12.7 (323)
Ethane	4.2 (107)
Ethylene	5.0 (127)
Helium	0.3 (8.0)
Hydrogen	0.06 (1.5)
Methane	3.7 (94)
Digester Gas: 50% CH ₄ , 50% CO ₂	7.0 (180)
Digester Gas: 60% CH ₄ , 40% CO ₂	6.3 (160)
Digester Gas: 70% CH ₄ , 30% CO ₂	5.6 (142)
Nitrogen	7.2 (183)
Oxygen	8.3 (211)
Propane	3.5 (89)
Special Gases – Consult Kurz	

Note 1: The Estimated Standard Drop (DP_S) is the end-to-end pressure drop at standard Conditions at the Baseline Flow Rate (Q*) listed in Table 2.

NOMENCLATURE:

SENSOR TYPE	
Identifier	Description
MD	"Mini-Dual" MetalClad™ all-welded sensor, .074" diameter elements.
FD2	"Fast-Dual" MetalClad™ all-welded sensor, 0.105" diameter elements.

GAS CATEGORY AND GAS TYPE	
Category	Gas Type
1	Air, Nitrogen, Oxygen, Argon, Carbon Dioxide, Dry Cl ₂
2	Methane, Digester Gas, Dry Ammonia
3	Ethylene
4	Ethane
5	Helium, Propane, Butane
6	Hydrogen

END CONNECTION TYPES		
Identifier	Description	Pressure Rating (PSIG)
MNPT	Male Pipe Threads (USA)	150
CL150	Class 150 ANSI B16.5 Raised Face Flanges	150
CL300	Class 300 ANSI B16.5 Raised Face Flanges	300

FLOW AREA	
Identifier	Description
A*	Area (FT ²) of effective flow area at the sensor location.

DEFINITIONS FOR THE USE OF TABLES 1, 2, 3 AND 4:

$$\text{Equation 1: } DR_p = \frac{P_p}{P_s} \times \frac{T_s}{T_p}$$

$$\text{Equation 2: } Q_{MAX} = F^* \times Q^*$$

$$\text{Equation 3: } DP_p = \frac{1}{DR_p} \times \left(\frac{Q_p}{Q^*}\right)^2 \times DP_s$$

Q* = Baseline Flow Rate as listed in Table 2 (SCFM for English Units or NCMH for Metric Units).

Q_p = Process Flow Rate (SCFM for English Units, NCMH for Metric Units).

Q_{MAX} = Maximum flow rate for a specific gas type and model number.

F* = Flow Factor (see Table 3).

T_s = Standard Process Absolute Temperature: 537°R (77°F + 460) for English Units or 273°K (0°C) for Metric Units.

T_p = Process Absolute Temperature: °R (T°F + 460) for English Units or T°K (T°C + 273°C) for Metric Units.

P_s = Standard Absolute Pressure (14.69 PSIA for English Units or 760 mm Hg for Metric Units).

P_p = Process Absolute Gas Pressure (PSIA for English Units and mm Hg for Metric Units).

DR_p = Process Gas Density Ratio.

DP_p = Estimated Pressure Drop at Process conditions (inches water or millimeters of water).

DP_s = Standard Pressure Drop (See Table 4, use either inches of water for English Units or millimeters of water for Metric Units).

Part Number Generation Procedure

With the selected Parent Number, specify the entire Part Number by selecting an Option for each Feature as shown in the example below. Feature Options in Bold type indicate the most available Models, other options usually require a longer delivery time.

Example Part Number for a Model 534FTB-16C:

755449 **A** **32** **B** **1** **F** **010** **A** **015** **B** **537**

Parent Number F1 F2 F3 F4 F5 F6 F7 F8 F9 F10

SUMMARY OF FEATURES	
Feature	Feature Description
1	Electronics Enclosure Configuration/Input Power, LCD/Keypad
2	Sensor Material/Flow Body Material
3	Flow Body Connection Type
4	Process Temperature Compensation
5	Gas Flow Rate Calibration Data Range
6	Specialty Gas Flow Rate Calibration
7	Safety Approval
8	Process Pressure
9	Analog & Digital Inputs/Outputs
10	Process Temperature

SERIES 534FTB IN-LINE THERMAL MASS FLOW TRANSMITTERS

FEATURE 1: ELECTRONICS ENCLOSURE CONFIGURATION AND INPUT POWER (See Note 1)	
Option	Description
A	Directly Attached Dual-Chamber Electronics Enclosure, AC-Power, LCD/Keypad.
B	Directly Attached Dual-Chamber Electronics Enclosure, AC-Power, without LCD/Keypad.
C	Directly Attached Dual-Chamber Electronics Enclosure rotated 180° for viewing, AC Power, LCD/Keypad.
D	Remote Dual-Chamber Electronics Enclosure, AC-Power, LCD/Keypad.
E	Remote Dual-Chamber Electronics Enclosure, AC-Power, without LCD/Keypad
F	Directly Attached Dual-Chamber Electronics Enclosure, 24VDC-Power, LCD Keypad.
G	Directly Attached Dual-Chamber Electronics Enclosure rotated 180° for viewing, 24VDC-Power, LCD/Keypad.
H	Directly Attached Single-Chamber Electronics Enclosure, 24VDC-Power, without LCD/Keypad.
I	Remote Dual-Chamber Electronics Enclosure, 24VDC-Power, LCD/Keypad.
J	Remote Single-Chamber Electronics Enclosure, 24VDC-Power, without LCD/Keypad.

Note 1: The conduit or cable seal must be installed by an experienced and careful installer to prevent water intrusion into the enclosure and to maintain the enclosure rating. Failure to properly install the conduit seals may void the Kurz warranty and may compromise the safety approval rating.

Note 2: Stainless Steel Identification Tags are available. Customer must provide labeling information up to four lines of text with 32 characters each line.

FIRST DIGIT OF FEATURE 2: SENSOR MATERIAL	
Option	Description
3	Alloy C-276

SECOND DIGIT OF FEATURE 2: FLOW BODY MATERIAL	
Option	Description
2	316L Stainless Steel

FEATURE 3: FLOW BODY CONNECTION TYPE		
Option	Description	Pressure Rating(PSIG)
A	Male NPT Pipe Ends (MNPT)	150
B	Class 150 ANSI B16.5 Flanges (CL150)	150
C	Class 300 ANSI B16.5 Flanges (CL300)	300

FEATURE 4: PROCESS TEMPERATURE COMPENSATION	
Option	Description
1	Standard Temperature Compensation over process temperature range of -40°C to +125°C for all gases. Uncertainty (SCFM): ±1% of Reading + (A*) (20 SFPM) above or below 25°C (Note 1). A* is the flow area of the 534FTB, see Table 1. Requires a minimum of three unobstructed inlet pipe diameters and two unobstructed outlet pipe diameters.

Note 1: An uncertainty specification of ± 0.025%/°C + (A*)(0.25 SFPM/°C) should be added for temperatures above or below standard.

FEATURE 5: GAS FLOW RATE CALIBRATION DATA RANGE (Note 1)			
Option	Description	Option	Description
A	100% of Q _{MAX}	I	60% of Q _{MAX}
B	95% of Q _{MAX}	J	55% of Q _{MAX}
C	90% of Q _{MAX}	K	50% of Q _{MAX}
D	85% of Q _{MAX}	L	45% of Q _{MAX}
E	80% of Q _{MAX}	M	40% of Q _{MAX}
F	75% of Q _{MAX}	N	35% of Q _{MAX}
G	70% of Q _{MAX}	P	30% of Q _{MAX}
H	65% of Q _{MAX}	Q	25% of Q _{MAX}

Note 1: Determined using Tables 2 & 3 and Equations 1 & 2

FEATURE 6: SPECIALTY GAS FLOW CALIBRATION
There are two gas flow calibration methods available: 1. Laboratory Gas Flow Calibration 2. Correlation Gas Flow Calibration in which the In-Line Mass Flow Transmitter is calibrated in air and experimentally derived correlation factors are used to obtain calibration data for the required gas type. For either type of calibration select the option that is equal-to-or-greater than Process Flow Rate (Q _p) calculated using Feature 5 and Table 2.

FEATURE 6: SPECIALTY GAS FLOW CALIBRATION (Note 1)		
Laboratory Calibration Option	Gas	Correlation Calibration Option
010	Air	-
070	Compressed Air	-
-	Dry Ammonia	560
080	Argon	580
-	Butane	600
140	Carbon Dioxide	640
-	Dry Chlorine	680
200	Ethane	700
220	Ethylene	720
260	Helium	760
280	Hydrogen	780
320	Methane	820
350	"Digester Gas" 50% CH ₄ , 50% CO ₂	850
360	"Digester Gas" 60% CH ₄ , 40% CO ₂	860
370	"Digester Gas" 70% CH ₄ , 30% CO ₂	870
400	Nitrogen	900
440	Oxygen (Note 2)	940
460	Propane	960

Note 1: Laboratory Gas calibrations are performed with gases of high purity and are NIST Traceable. Customer must specify calibration pressure (Feature 8). Propane to 50 PSIA, all other gases to 150 PSIA. Correlation calibrations are based on experimental data correlated to an air calibration at ambient pressure and temperature. The user's flow element is calibrated in air, and an additional calibration data sheet is made for the specialty gas based upon the correlation factors. Add ±5% of Reading to the accuracy specifications when using a gas correlation calibration. All correlations include VTM.

Note 2: It is the customer's responsibility to insure that the Mass Flow Element is clean of Hydrocarbons and is safe for oxygen use. (See Accessories in Section C-1 for Cleaning and Bagging).

SERIES 534FTB IN-LINE THERMAL MASS FLOW TRANSMITTERS

FEATURE 9: SAFETY APPROVALS (Note 1)	
Option	Description
A	Non-Incendive (NI), CSA, ATEX and IECEx Ex nA II, T6, T5, T4 or T150° C (electronics enclosure) Ex nA II, T5 or T3 (sensing element)
B	Explosion-Proof/Flame-Proof, CSA, ATEX and IECEx Ex d IIB + H2, T6, T4, T110° C or T150° C (electronics enclosure) Ex d IIB + H2, T4 or T3 (sensing element)

Note 1: See Specifications, Page 5.

FEATURE 8: PROCESS PRESSURE
Enter the Absolute Pressure (PSIA), rounded off to 3 digits. Example: For a Process Absolute Pressure of 14.7 PSIA, enter 015; for 150 PSIA, enter 150.

FEATURE 9: ANALOG & DIGITAL INPUTS							
Option	ANALOG & DIGITAL INPUTS				COMMUNICATION PROTOCOLS		
	No. of Alarm Relay Outputs (DO)	No. of 4-20mA Outputs (AO)	No. of Digital Inputs (DI)	No. of 4-20mA Inputs (AI)	USB	Modbus RS-485 RTU or ASC II	HART (FSK 7.0)
B ¹	0	2	0	0	Yes	Yes	No
C ²	2	2	2	1	Yes	Yes	No
E ³	2	1	2	1	Yes	Yes	Yes

1 Option B provides:

- Two 4-20 mA outputs for Flow Rate and/or Temperature, NAMUR NE-43 compliance.
- USB, Modbus and RS-485 communication protocols.

2 Option C provides:

- Two 4-20 mA outputs for: Flow Rate, Temperature, EPA Zero-MidSpan-Span Drift check ^{III} or PID Flow Control ^{I,II}, NAMUR NE-43 compliance.
- Two alarm relays for: Flow Rate, Temperature or Pulsed Flow Totalizer. External 4-20 mA input.
- DI for EPA Zero-MidSpan-Span Drift Check initiation.
- USB, Modbus and RS-485 communication protocols.

3 Option E provides:

- One 4-20 mA output for: Flow Rate, Temperature, EPA Zero-Mid-Span Drift check ^{III} or PID Flow Control ^{I,II}, NAMUR NE-43 compliance.
- Two alarm relays for: Flow Rate, Temperature or Pulsed Flow Totalizer. External 4-20 mA input.
- DI for EPA Zero-MidSpan-Span Drift Check initiation.
- HART Communication Interface, USB, Modbus and RS-485 communication protocols.

Notes:

- The PID Flow Controller uses one 4-20 mA output for the flow controller.
- The External Input PID Controller requires a 4-20 mA flow reference input.
- EPA Zero-MidSpan-Span Drift check normally requires a contact closure to verify that the Drift Check has been truly indicated. The contact closure is generated by the Continuous Emissions Monitor Computer at a specific time every day to indicate the Daily Drift Check. Both 4-20mA outputs are used during the Drift Check Calibration procedure.

FEATURE 10: PROCESS TEMPERATURE
Enter the Absolute Process Temperature (° Rankin = °F + 460) rounded off to 3 digits. Example: For a Process Temperature of 77° F, enter 537.

SERIES 534FTB DIMENSIONS & WEIGHTS

SERIES 534FTB IN-LINE THERMAL MASS FLOW TRANSMITTERS							
Model Number	Pipe Size (NPT)	Dimensions (See Note 1)			Net Wt. Lbs. (See Note 2)		
		L (in)	L1 (in)	H (in)	MNPT	CL150	CL300
534FTB-06A	½"	9	6.17	9.96	6.7	8.2	9.2
534FTB-06B	¾"	9	6.17	9.96	6.8	9.1	11.2
534FTB-06C	1"	9	6.17	9.96	7.0	10.1	12.6
534FTB-08A	½"	15	6.23	9.96	7.4	8.9	9.9
534FTB-08B	¾"	15	7.23	9.96	7.6	9.9	12.0
534FTB-08C	1"	15	8.23	9.96	7.6	10.7	13.2
534FTB-12A	¾"	20	6.67	10.08	9.6	11.9	14.0
534FTB-12B	1"	20	7.54	10.08	9.3	12.4	14.9
534FTB-12C	1½"	20	9.98	10.08	9.9	15.0	20.0
534FTB-16A	1"	26	7.48	10.21	11.9	15.0	17.5
534FTB-16B	1½"	26	9.79	10.21	11.8	16.9	21.9
534FTB-16C	2"	26	11.67	10.21	12.5	20.5	23.6
534FTB-24A	1½"	38	4.00	9.28	18.5	23.6	28.6
534FTB-24B	2"	38	5.96	9.28	18.8	26.8	29.9
534FTB-24C	3"	38	10.75	9.28	N/A	35.2	42.6
534FTB-32A	2"	48	4.87	9.54	26.6	34.6	37.7
534FTB-32B	3"	48	9.52	9.54	N/A	42.9	50.3
534FTB-32C	4"	48	13.68	9.54	N/A	49.0	66.7
534FTB-48A	3"	72	7.18	13.18	N/A	72.4	N/A
534FTB-48B	4"	72	11.24	13.18	N/A	78.6	N/A
534FTB-48C	6"	72	20.00	13.18	N/A	87.5	N/A
534FTB-64A	4"	94	9.18	13.18	N/A	122.6	N/A
534FTB-64B	6"	94	17.82	13.18	N/A	131.4	N/A
534FTB-64C	8"	94	26.12	13.18	N/A	151.9	N/A

Notes:

1. Add 3" to L and 1½" to L1 for MNPT option.
2. Add 3.3 lbs. for AC Power options; add 4 lbs. for remotely attached Electronic Enclosure options.

SERIES 534FTB OUTLINE DRAWINGS

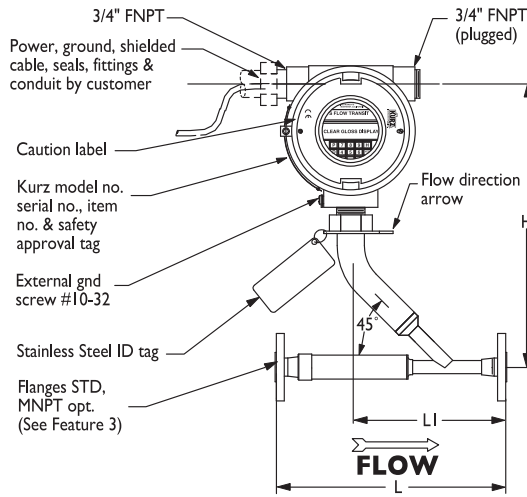

Directly Attached Dual-Chamber Electronics Enclosure
 Shown with Model 534FTB -08B
 Feature 1, Options A, F (Shown with Display in Standard Display Orientation)

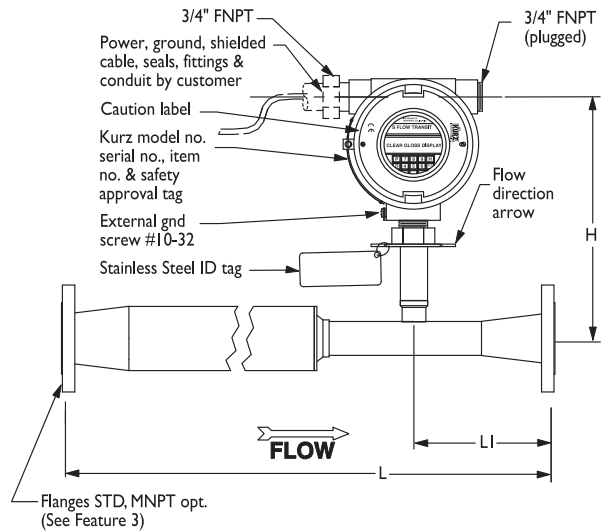

Directly Attached Dual-Chamber Electronics Enclosure
 Shown with Model 534FTB -48B
 Feature 1, Options A, F (Shown with Display in Standard Display Orientation)

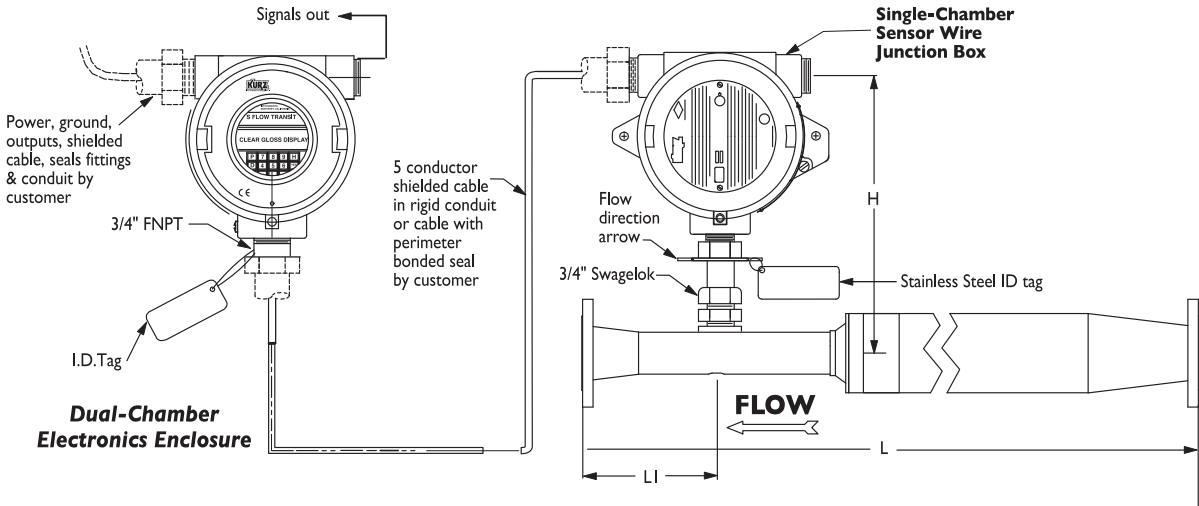

Remote Dual-Chamber Electronics Enclosure
 Feature 1, Options D, I Shown with Model 534FTB -48B

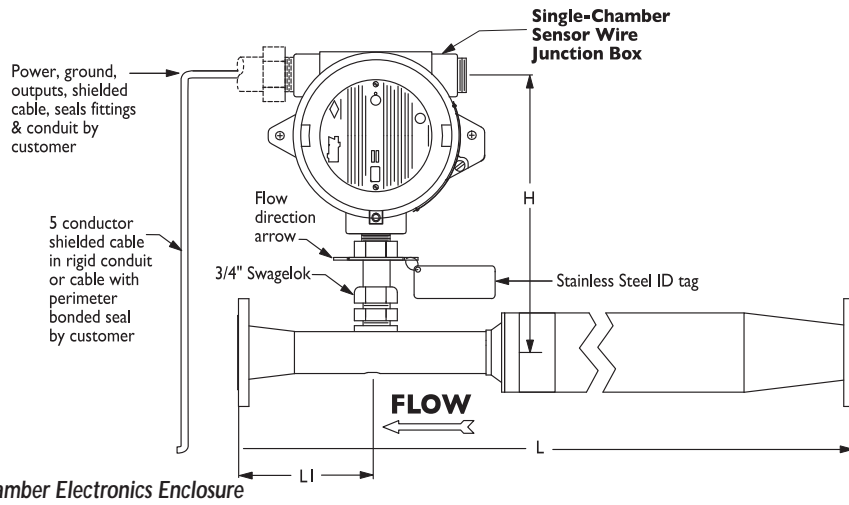

Directly Attached Single-Chamber Electronics Enclosure
 Feature 1, Option H (DC Powered without Display) Shown with Model 534FTB -48B

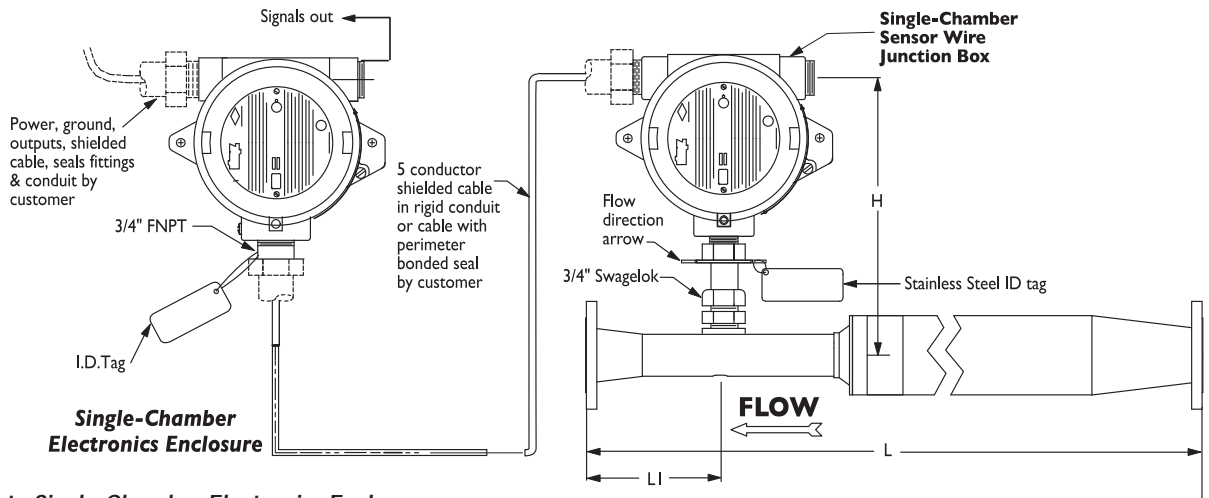

Remote Single-Chamber Electronics Enclosure
Feature 1, Option J (DC Powered without Display) Shown with Model 534FTB -48B

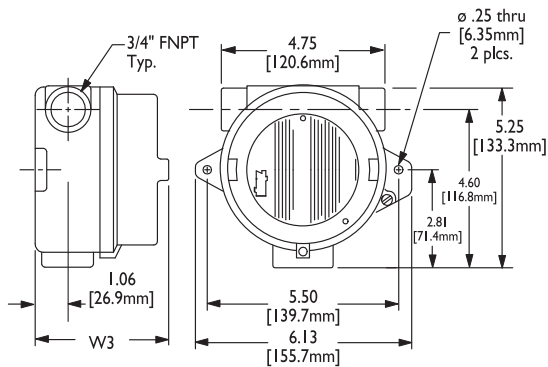

Single-Chamber Sensor Wire Junction Box,
Single-Chamber Electronics Enclosure Dimensions

Enclosure Type	W ₃
Junction Box	3.88 [99mm]
Electronic Enclosure	5.94 [151mm]

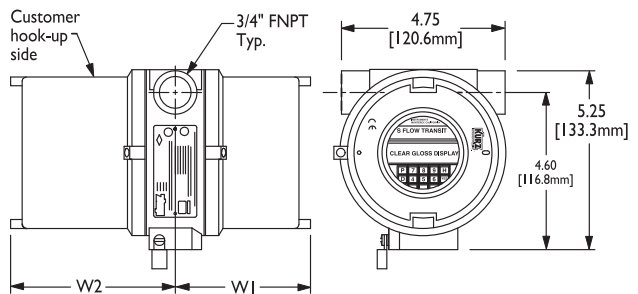

Dual-Chamber Electronics Enclosure Dimensions

Input Power	Display/Keypad	W ₁	W ₂
AC	Yes	3.41" (87mm)	4.69" [119mm]
AC	No	2.75" [70mm]	4.69" [119mm]
24 VDC	Yes	3.41" [87mm]	4.69" [119mm]

*The leader in Mass Flow
Technology for Process and
Environmental Measurements*



Kurz Instruments, Inc.

2411 Garden Road, Monterey, CA 93940

800-424-7356 ■ 831-646-5911 ■ Fax 831-646-8901

www.kurzinstruments.com

e-mail: sales@kurzinstruments.com