

KURZ™ INSTRUMENTS, INC.

**Model 435DC
Linear Air Velocity Transducers
User's Guide**

Customer Name:

P.O. Number:

Date of Order:

Complete Model Number:

Kurz™ Order Number:

Serial Number:

Document Number: 360141, Rev. A

TABLE OF CONTENTS

Section 1	<i>Description</i>
Section 2	<i>Principle of Operation</i>
Section 3	<i>Operating Instructions</i>
Section 4	<i>Applications</i> <i>A: Air Velocities in Open Spaces</i> <i>B: Velocities and Flow Rates in Ducts</i>
Section 5	<i>Specifications</i>
Section 6	<i>Quick Guide to Hooking up the 435DC</i>
Section 7	<i>Parts Layout & Schematic Diagrams</i>
Section 8	<i>Warrenty Statement</i>

Section 1
DESCRIPTION

430/435

Air Velocity System

Kurz Models 430 and 435* are general purpose, bench-top or permanent installation, low-cost velocity and mass flow measurement systems operated on line voltage.** The output voltage, suitable for recording and other purposes is 0 to 5VDC for several choices of air velocity. The **Model 430** features excellent accuracy and repeatability and outstanding low-speed sensitivity (down to a few feet-per-minute). The non-linear output voltage allows excellent accuracy and a rangeability of at least 100:1. The **Model 435** has a linear 0-5VDC output voltage suitable for display, recording and totalizing.

The **430 and 435 Air Velocity System** comes complete with the unique, rugged "**DuraFlo**"™ probe, a retractable, removeable probe shield, and electronic package housed in a rugged, weather-resistant enameled steel enclosure, 15 foot probe cable and 6 foot power cord.

The **Model 430 and 435** can be used as an insertion probe in ducts and pipes for the measurement of velocity or total mass flow rate of air flow in a variety of applications.

Several different velocity ranges are available. Metric scales, operation at 220 VAC/50 HZ and high temperature models are also available. Please see Section 5 for complete specifications.

Section 2

PRINCIPLE OF OPERATION

The basic sensing element of the **Models 430 and 435** is the unique "**DuraFlo**"™ probe. The "**DuraFlo**"™ probe consists of two integral sensors: a velocity sensor and a temperature sensor. The velocity sensor is a constant-temperature thermal anemometer which measures "standard" velocity (referenced to 25° C and 760 mm Hg), or mass flow, by sensing the cooling effect of the moving flowstream as it passes over the heated sensor. The sensor is heated electrically by the control circuitry in the electronics package. The velocity sensor is rugged and large. It is not a fragile hot wire and therefore is breakage resistant and insensitive to particulate contamination. The temperature sensor accurately compensates for temperature variations over a wide range. The probe is used directly to measure air velocity in open spaces, ducts and supply and return openings.

It should be noted that the velocity readings of the **Models 430 and 435** are referenced to standard conditions of 25° C and 760 mm Hg pressure. Each system directly measures the local mass velocity of the air. In order to obtain the actual velocity a simple density correction may be used as follows:

$$V_{act} = V_{ind} \frac{d_s}{d_a}$$

Where: d_s = air density at standard conditions of 25° C and 760 mm Hg

d_a = actual density at local temperature and barometric pressure,

V_{act} = actual air velocity in feet per minute, and

V_{ind} = indicated velocity on Model 430/435

Section 3

OPERATING INSTRUCTIONS

The **Model 430 and 435** are line-powered instruments. The probe is preconnected to the electronics enclosure. If an option such as the **Model 438** Analog Readout or **Model 439** Digital Panel Meter is purchased, it will be preconnected at the factory.

To operate, plug the power cable into a standard 3-wire grounded outlet. Loosen the knurled nut on the probe shield and slide the shield toward the cable, exposing the sensor. Tighten the knurled nut to secure the probe shield. Be certain that the "window" cut-out in the probe is positioned such that the air passes through and impinges on the sensor. If the probe is used to traverse a duct, the axial and concentric markings can be used to orient the probe and to measure the insertion depth. **Always slide the retractable probe shield over the sensor when the system is not in use to avoid possible breakage.** Also, always make certain that the power cord is removed when connections are made or disconnected to avoid electrical shock hazard and possible damage to the probe and electronics.

Section 4 APPLICATIONS

A. Air Velocities in Open Spaces or Single-Point Measurements

The **Models 430 and 435** are easily used to measure local air velocities in a wide variety of applications. Simply retract the probe shield and place the probe perpendicular to the air flow expected. The window in the probe tip should be rotated such that the flow passes directly through it. You will notice that the output is not affected greatly by angular rotation of the probe until a change of about $\pm 40^\circ$ to the flow direction.

For extremely low velocities, it is recommended that the probe be firmly attached to a tripod, wall, beam or other structure in order to eliminate movement of the probe.

In situations in which the air temperature is changing, let the probe come to thermal equilibrium, thus allowing time for the temperature compensation features of the air velocity meter to respond.

B. Ventilating Openings

Models 430 and 435 can be conveniently used to obtain the velocity and total flow of supply and return openings or suction openings. In either case, place the probe close to and parallel to the surface of the opening, allowing the air to flow perpendicularly through the window in the probe tip.

When it is necessary to obtain the total flow of a supply or return opening having no grill, use the equation:

$$Q = A \bar{V},$$

Where:

Q = quantity of air in standard cubic feet per minute (SCFM),

A = area of the opening in square feet, and

\bar{V} = the area-weighted average air velocity in standard feet per minute,

To determine the average air velocity, divide the opening into a number of equal areas. Take a velocity reading at the center of each area and numerically average the results. If the velocity profile is relatively flat, only a few areas need be taken; if the profile is non-uniform several areas should be used. Generally, it is a good idea to make a rapid traverse across the duct in two dimensions to determine the uniformity of the air velocity. If the velocity is not constant at one measuring point, use the mean velocity between the upper and lower readings. Generally the velocity profile is more uniform on suction openings than on supply openings.

If a supply opening is covered by a grill, it is suggested that the probe be placed about 1" in front of the grill to obtain the average velocity reading as above. The Area, A, used in the above equation is the core area of the grill.

If information is given on the coefficient of discharge for a specific grill, the probe should be placed against the grill and centered over the open areas in the grill. Choose several grill openings to obtain an average air velocity. In this case the total flow is

$$Q = K A \bar{V},$$

Where: K = the given coefficient of discharge and

A = area of the grill as specified by the manufacturer

For openings covered by diffusers, please refer to the manufacturer's instructions for the particular type of diffuser. This information is usually available.

If a return or suction opening is covered by a grill and it is necessary to compute the total flow into the opening, the correct procedure is to take a number of readings at

the center of equal area, as in the case of having no grill, and determine the average velocity. The probe should be placed in the plane of the opening and close to the grill. The flow rate can be computed fairly accurately by the following equation:

$$Q = F A \bar{V},$$

Where:

Q = flow rate in standard cubic feet per minute,

F = application factor (see following table),

A = designated area in square feet, and

\bar{V} = average velocity in standard feet per minute.

Grill Type	Application Factors, F	Designated Area
No Grill	1.00	Full Duct Area
Square Punched Grill	0.88	Free (daylight) Area
Bar Grill	0.78	Core Area
Steel Strip Grill	0.73	Core Area

For applications requiring higher accuracy, it is suggested that a duct extension be used having a length of at least the largest dimension of the grill. This duct extension is placed against the grill, and the procedures for an open grill are followed to compute the flow rate. For highest accuracy a smoothly-tapered flow nozzle should be placed over the supply grill. The velocity profile at the exit jet of such a nozzle will be very flat.

C. Velocities and Flow Rates Inside Ducts

Since air velocities are rarely uniform across a duct or even symmetric, it is usually necessary to submit to the time-consuming process of obtaining the average velocity within the duct. Whenever possible, choose a measurement location at least 10 duct diameters downstream from the nearest elbow, tee, bend, valve, or flow obstruction.

The procedure is to divide the flow areas into several equal areas and take a velocity reading at the center of each area. The number of such equal areas will increase as the velocity profile becomes more uniform. These readings are then averaged arithmetically to obtain the average velocity. This total flow rate is then:

$$Q = \bar{V} A,$$

Where:

Q = flow rate in standard cubic feet per minute,

\bar{V} = average velocity in standard feet per minute, and

A = area of duct in square feet.

A common procedure is to traverse the probe once horizontally and once vertically to obtain the proper velocity readings. Figure 4-1 shows non-dimensional probe traverse locations for equal-area readings in round and square ducts. To obtain faster results less points can be used with a corresponding sacrifice in accuracy. Please note that locations #1 in Figure 4-1 has an area equal to four times the areas of the other locations and is accounted for properly in the example which follows.

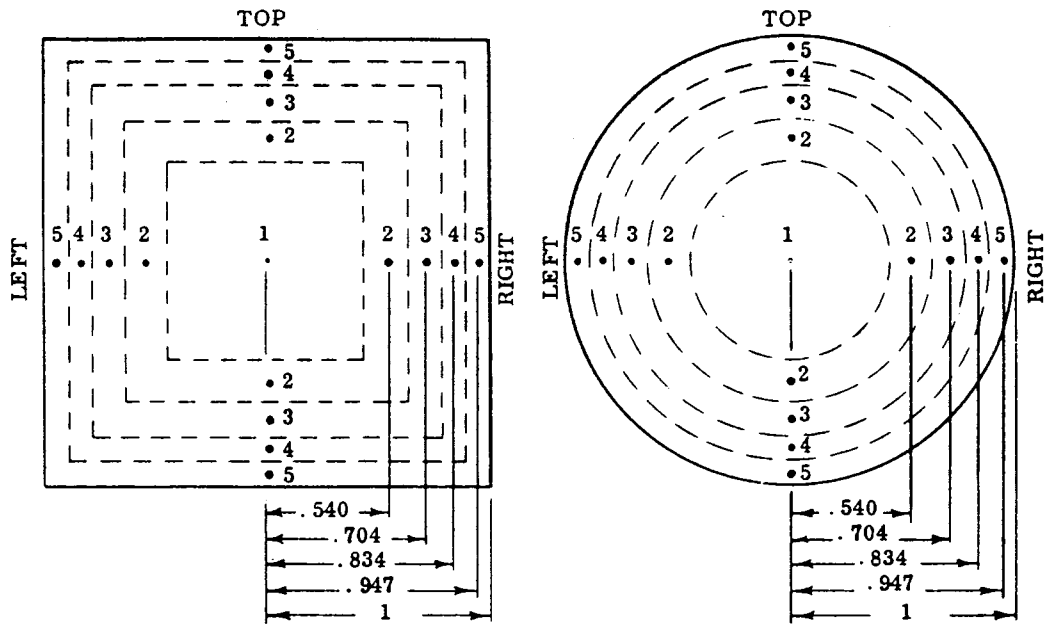

Figure 4-1: Equal-Area Traverses for Square and Round Ducts

To make the traverse, drill two $17/64$ " diameter holes in the side of the duct, spaced 90° to each other. Be careful not to create a jagged hole which may disturb the measurements. Note that the probe is marked in 1-inch increments starting from the center of the velocity sensor. The first mark, therefore, is one inch from the sensor, and the mark closest to the probe cable is 12 inches from the velocity sensor. For ducts having a diameter greater than about 6 inches, the probe shield must be removed. Use a ruler to position the probe at the appropriate location, using the marks on the ruler for reference. The probe also is scribed axially from one end to the other to allow the operator to align the probe window with the flow. Since the window in the probe is about $15/16$ inches long, it is not normally possible to obtain accurate velocity measurements near the traverse hole in the duct because of a possible leakage path through the window to the outside of the duct. Such a leakage may affect the velocity reading of the sensor. If the probe is inserted into the duct past the window in the probe, accurate measurements are obtained. It is therefore suggested that the edge measurement near the two traverse holes be ignored and that the average velocity measurements taken at the opposite wall be substituted. This procedure involves very little error in the overall measurement. After the measurements are completed, be sure to seal the traverse holes.

A numerical example illustrating the averaging process is given below for a 6" square duct.

	Location					Sum	Average
	1	2	3	4	5		
Left	1200	1150	1100	1000	700	5150	1030
Right	1200	1140	1115	1020	700	5175	1035
Top	1200	1200	1175	1100	800	5475	1095
Bottom	1200	1175	1150	1050	800	5375	1075
Sum	4800	4665	4540	4170	3000	21,175	4235
Average	1200	1166	1135	1043	750	5294	1059

Thus the average velocity is 1059 standard feet per minute (SFPM).
The total flow is:

$$Q = A \cdot \bar{V} = .5 \text{ ft.} \times 0.5 \text{ ft} \times 1059 \text{ SFPM, or}$$

$$Q = 264.75 \text{ SCFM.}$$

Section 5 SPECIFICATIONS

The specifications for the **Models 430 and 435** as well as the **Models 415 and 455** are listed in detail in the product sheets on the following pages. (For Series 425 or 435B Digital Bench Cabinets, a 3rd brochure covering these items will also be present).

SPECIFICATIONS:

Accuracy: + or - (3% +.5% full scale)

Repeatability: + or - 0.25%

Response Time: 1 Second typical, 35 millisecond optional

Power Requirement: 15Vdc, 500ma

Calibration: NBS Traceable in Air. Included.

Optional Specialty Gas Calibrations

Output Signal: Linear 0 - 5Vdc

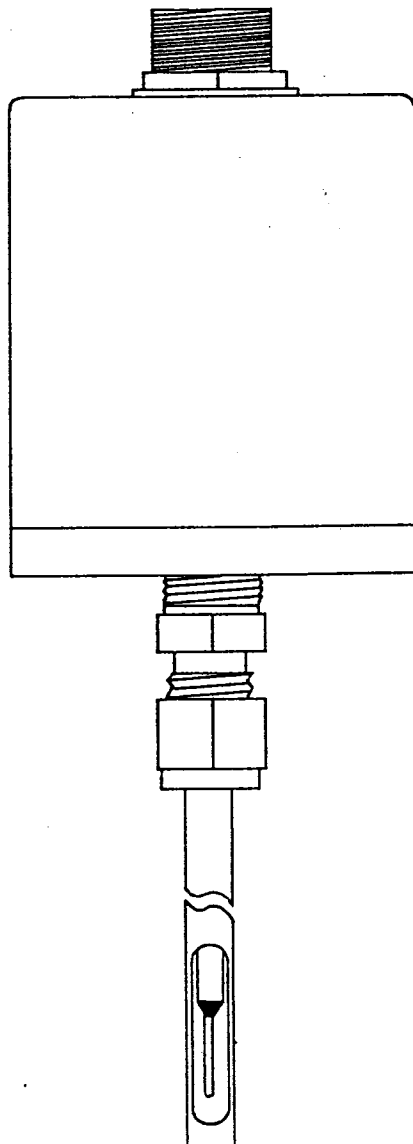

QUICK GUIDE TO HOOKING UP THE 435-DC

Top View

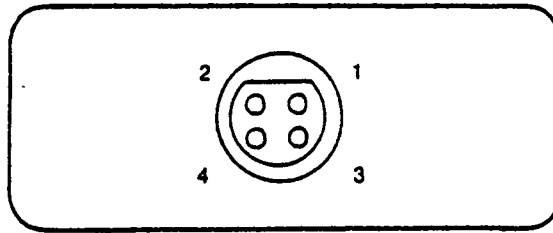

PIN DESCRIPTION

Wire Color	Pin No.	Description
Green	1	Power In, Low \
Red	2	Power In, High / see Power Supply Requirements
White	3	Signal Out, High \
Black	4	Signal Out, Low / see Output Signal Characteristics

NOTE:

Pin 1 (Power In, Low) and Pin 4 (Signal Out, Low) can be connected and share a common ground.

REVISED LINEAR OUTPUT W/ 228 11 1/2 1/2

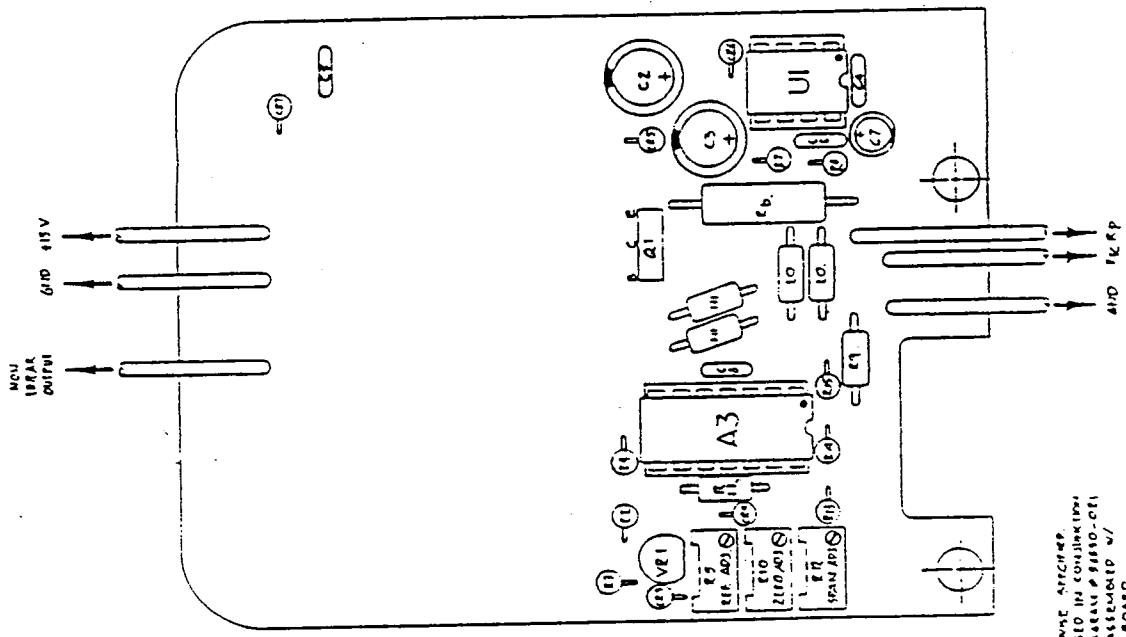

REF ID	DESCRIPTION	REVISION
R1, R2, R3	RESISTOR SELECTED (TEMP. COMP)	
R11, R12	SELECTED (FOR ZERO A SPAN)	
R13, R14	1.0 1K	
R6	1K	
R9	500K	
R15, R16	RESISTOR 10K	
R10, R11	POTENTIOMETER 1K, 50 W/100	
R7	POTENTIOMETER 20K, 50 W/200	
C1	CAPACITOR 10 ^u F 25V	
C2, C3, C4	0.1 ^u F 50V	
C5	CAPACITOR 0.001 ^u F 50V	
C6, C7	DIODE 1N914	
Q1	TRANSISTOR 2N130	
VE1	VOLAGE REGULATED LM332 2.5V	
U1	IC, THREE 825	
T1	8 PIN DIP SOCKET	
	14 PIN DIP SOCKET	
	8 PIN IC SOCKET	
REF ID		

NOTES: 1. THIS PCB TO BE USED IN A SHIELDING CAN. 2. ALL POINTS TO BE ASSEMBLED W/ CALIBRATED TO PCB BOARD.

Kurz Instruments, Inc.
Model 430DC
Component Layout

DATE: 5/1
C 56530022
DO NOT SCALE DRAWING

REV.	DESCRIPTION	DATE	APPROVED
LTR			

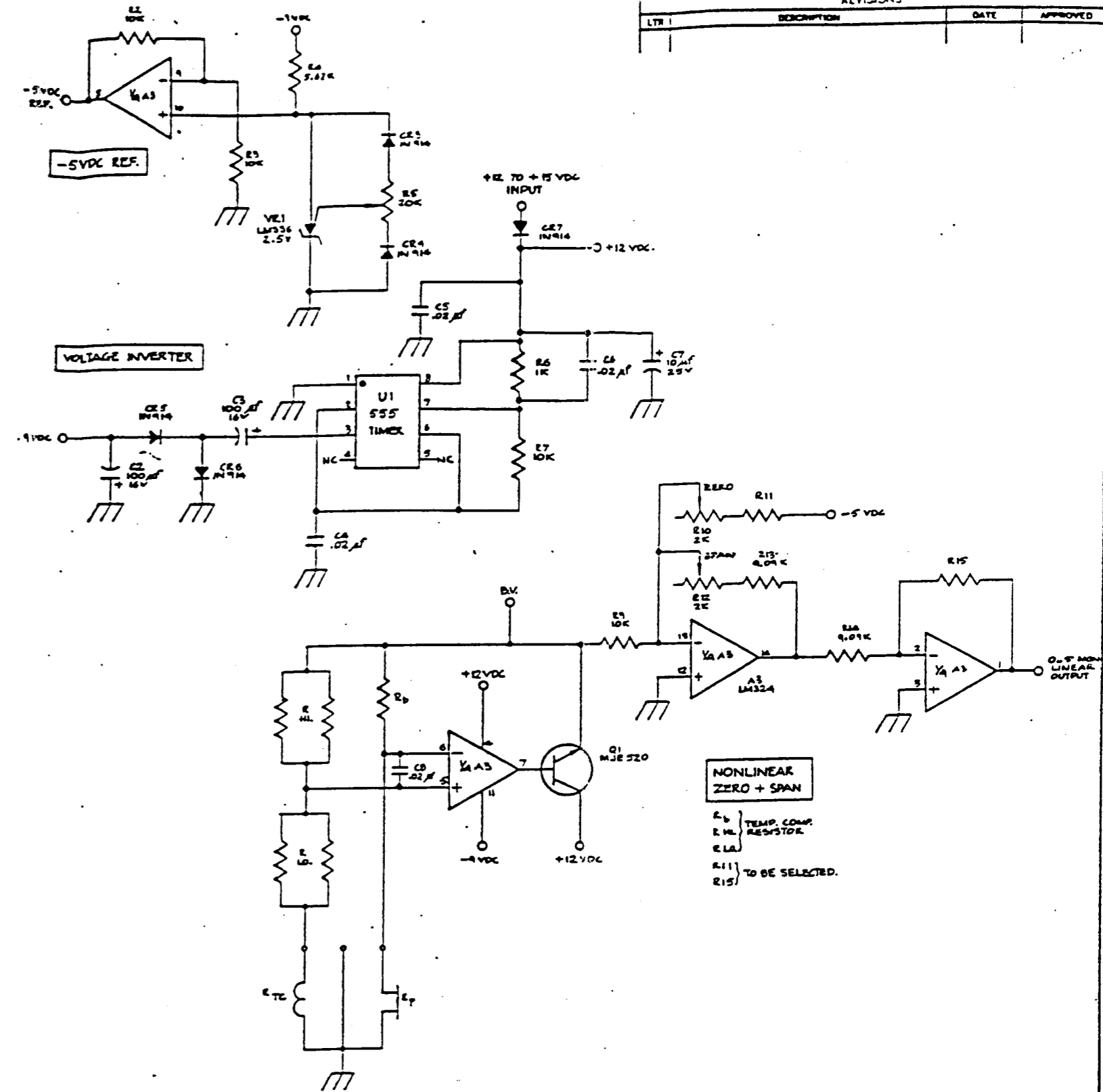

2. LAST REF. DEG. USED = A3, U1, Q1, CR7, C8, R15.
 1. THIS DWG. TO BE USED IN CONJUNCTION W/ COMPONENTS LAYOUT # 56530-022.
 NOTES.

TOLERANCES UNLESS OTHERWISE SPECIFIED FRACTIONS DEC. ANGLES		Kurz Instruments, Inc.	
APPROVALS		Model 430DC	
DATE		Schematic Diagram	
DESIGNED	10-12-84	SCALE	NONE
CHECKED	10-12-84	SIZE	C
DATE	10-12-84	DRAWING NO.	C56530021
DO NOT SCALE DRAWING		SHEET 1 OF 1	

WARRANTY STATEMENT

All products from Kurz Instruments Inc. are warranted against defective materials or workmanship to the original purchaser for a period of one year from the original purchase date, under normal use and service.

Defective parts will be repaired, adjusted, and/or replaced at no charge when the instrument is returned prepaid to Kurz Instruments Inc. Please call for a Return Authorization Number.

The warranty is VOID if the instrument has been visibly damaged by accident, misuse, or has been serviced or modified by any person other than Kurz Instruments Inc.

This warranty contains the entire obligation of Kurz Instruments Inc. and no other warranties expressed, implied, or statutory are given.